



# Triathlon **PINK**



**16 March 2025**

**Stromlo Forest Park**

# **CANBERRA**

# WELCOME MESSAGE



Triathlon Pink was founded in 2007 with just two events in Sydney and Melbourne, marking a fantastic new initiative for the Australian sporting community, exclusively for women.

The events offer participants, affectionately known as 'Pinkies,' a challenging yet fun and safe experience. **Triathlon Pink** aims to encourage women to participate, have fun with friends and family, and create lasting memories. The goals of Tri Pink include **CHALLENGE, PARTICIPATION, and FUN!** Pinkies can compete individually, completing the entire course on their own, or join a group of friends to compete as a team, similar to a relay.

Since its inception, over 85,000 women have crossed the finish line, making Tri Pink one of the most popular sporting events for women in Australia. Looking ahead to the 2024/2025 season, we anticipate welcoming over 5,000 participants, bringing the total to over 90,000 women who have experienced the Pinkie spirit!

A key aspect of Triathlon Pink is its close relationship with the National Breast Cancer Foundation (NBCF). Pinkies have successfully raised over \$2.5 million for NBCF. Triathlon Pink received the NBCF Patrons Award for Community Fundraising in 2010 and the NBCF Community Involvement Award in 2015. This cause is deeply meaningful to many participants, who have either battled breast cancer themselves or supported loved ones through their journey.

We look forward to sharing the events with you!

# EVENT TIMELINE

## SATURDAY 15 MARCH

TIME	ACTIVITY	LOCATION
2:00PM	Optional Event Check In opens	Event Check In
3:00PM	Optional Event Check In closes	Event Check In
2:30PM	Tips and Tricks Clinic	Event Check In

## SUNDAY 16 MARCH

TIME	ACTIVITY	LOCATION
6:00AM	Event Check-In opens all distances	Event Check In
6:00AM	Bike to Run Transition opens all distances	See Map
6:00AM	Pool Transition Opens (Kids 7-9, Men, Ultra, Long)	See Map
7:00AM	Kids 7-9yrs Course Briefing	Pool Area
<b>7:10AM</b>	<b>Kids 7-9yrs Triathlon Start</b>	Pool Area
7:20AM	Ultra / Men's Course Briefing	Pool Area
7:29AM	<b>Men's Pink Wave</b>	Pool Area
7:30AM	<b>Ultra Course Start</b>	Pool Area
7:40AM	<b>Kids 1km Fun Run Start</b>	Adjacent to Finish Line
7:40AM	Long Course Briefing	Pool Area
7:45AM	Pool Transition Opens (Medium)	See Map
7:45AM	<b>Long Course Start</b>	Pool Area
7:45AM	<b>10km, 5km &amp; 2.5km Fun Run Start</b>	Adjacent to Finish Line
7:55AM	Pool Transition Opens (Short, Kids 10-13)**	See Map
8:00AM	Medium Course Briefing	Pool Area
8:10AM	<b>Medium Course Start</b>	Pool Area
8:20AM	Short Course & Kids 10-13 Briefing	Pool Area
8:30AM	<b>Short Course Start</b>	Pool Area
8:30AM	<b>Kids 10-13yrs Start</b>	Pool Area
10:00AM	Event completed	Time to Celebrate!

- Please note that registration closes 20 minutes before the start time of your event and transition closes 15 mins before your race start.
- \*\* Please rack after 7.55am to reduce congestion in the transition area. Please listen out to staff in transition for when you can access this area. Racking can be done up to 15min before your event start time.
- **All participants can put their gear in Bike to Run Transition (please see map) at any time throughout the morning, please take note of the opening times of the Pool Transition area.**

## DISTANCE AND LAPS



<b>TRIATHLON PINK</b>	<b>SWIM</b>	<b>CYCLE</b>	<b>RUN</b>
<b>ULTRA</b>	600m 2 laps	19km 6 laps	7.5km 3 laps
<b>LONG</b>	300m 1 lap	9.6km 3 laps	5km 2 laps
<b>MEDIUM</b>	200m 1 lap	6.4km 2 laps	2.5km 1 lap
<b>SHORT</b>	100m 1 lap	3.2km 1 lap	1km 1 lap
<b>KIDS 10-13</b>	100m 1 lap	3.2km 1 lap	1km 1 lap
<b>KIDS 7-9</b>	50m 1 lap	2km 1 lap	500m 1 lap
<b>FUN RUN PINK</b>	10km 4 laps	5km 2 laps	2.5 & 1km 1 lap

Join the fun and race in style  
with **navi**



**Australian Made  
Activewear with a  
Purpose.**

**Advocating for  
Women's Health and  
Safe Sport.**

**Proud Sponsors of  
your TRI PINK  
journey.**

**Check out our range  
of triathlon suits, run  
shorts and more!**

**@naviforwomen**

**[www.naviforwomen.com](http://www.naviforwomen.com)**

# GENERAL EVENT INFORMATION

## I'VE ENTERED, WHAT HAPPENS NOW?

Race numbers (eKit) and Event Information emails will be emailed out on Thursday of race week.

## COLLECTION OF YOUR RACE PACK

Bring your race number with you to Event Check In - this is what you need to collect your race packs.

**GETTING TO THE VENUE** The Venue is at the Stromlo Forest Park and Leisure Centre.

**EVENT PHOTOGRAPHY** is provided at each event. A link to photos will be sent by email following the race.

**BEGINNERS INFO SESSION** If you are new to triathlon or would just like some additional info about the event, come to our Tips and Tricks Clinic at 3pm on Saturday during optional event registration. The session will run you through the event step by step and give you the chance to ask questions.

## TRANSITION INFO

**Triathlon Pink Canberra has TWO transition areas - one near the finish line and one near the pool.** Transition is where you change over for the swim-bike and bike-run legs of the race.

- Please collect your race pack and then set up in the Bike to Run Transition first.

- **Medium, Short and Kids 10-13.** Please note the transition split access times available (we do this to reduce congestion in the transition area). Please listen out to staff in transition for when you can access this area. Racking can be done up to 15min before your event start time.
- **If you are using cycling shoes during the bike section, please make sure you leave your cycling shoes at Pool Transition and your running shoes at Bike to Run Transition.**
- **Set-up in Bike to Run Transition:** Find the designated space to place anything you need for the run (ie. running shoes if you're using cycling shoes during bike leg). Make sure you take note of where you leave your gear so it is easy to find after your bike leg. Some ladies will not need to leave anything here.
- **Set-up in Pool Transition:** Find the bike rack allocated to your distance category, place your bike on the rack and set up your bike equipment to the right (chain side) of your bike. If you are using cycling shoes make sure these are with your bike.
- **Transition access:** Only competitors are allowed in transition area (ONE parent per child to assist set up prior to the Kids Triathlon only. No parents allowed in transition during the event)



## HOW DOES THE EVENT WORK?

### EVENT SET UP

After collecting your race pack, put all your stickers from your race pack on your bike and helmet and head in to transition to set up your gear. Ask one of the officials in transition if you are unsure what to do.

### SWIM

- Enter the pool one at a time and swim around the buoys in a zig-zag fashion.
- Your timing chip is activated as you cross the timing mat upon pool entry.
- If you want to stay with your friends, just line up directly behind each other as you get into the pool.
- It can take some time getting participants in the pool, so we recommend you sit in the shade while you wait.
- If you are a slow swimmer, we suggest you start at the back of the line.
- For assistance during the swim leg, raise your hand and call for a lifeguard.
- If you need a rest, simply hold onto the edge at the end of the pool.
- You can swim with a pool noodle for added buoyancy if you wish.

### BIKE

- After your swim, head to transition and put on your helmet.

- Take your bike off the rack and walk it to the mount line. **Please don't ride your bike in transition or on the way to the mount line.**
- Once you pass the mount line, get on your bike and ride your allocated number of laps.
- Always ride single file and keep to the left at all times unless overtaking.
- We recommend having a drink bottle on your bike to stay hydrated.
- Make sure your helmet is secured from the time you remove your bike from the rack until you put your bike back on the rack.

### RUN

- After your bike leg, get off your bike at the dismount line and **walk** your bike back to transition.
- Rack your bike then remove your helmet and get ready for the run.
- When ready, head towards the run start flag in transition to begin your run.
- Complete your allocated laps then head down the finish line on your final lap.
- There are drink stations along the run course so please make use of these to ensure proper hydration.
- Please **keep left** on the run course at all times unless overtaking.



### EVENT MERCHANDISE

On race day, every competitor will receive a timing chip, event gift and race bib at event check in. All Kids Tri, Classic Tri and Moreton Bay Running Festival participants will receive a finisher's medal in addition to this.

### WHAT TO BRING

#### SWIM

- Goggles
- Swim suit / tri-suit
- Sunscreen
- Swim cap (provided)
- Timing chip (provided)

#### BIKE

- Bike
- Bike shoes or running shoes
- Helmet
- Bike pump
- Spare tube / tyre lever (optional)
- Drink bottle

#### RUN

- Running shoes
- Socks
- Hat/ sunglasses
- Race number bib (provided)
- Race belt or pins to attach bib

### WHAT NOT TO BRING

Please leave all headphones at home - we have an insurance and safety requirement that you can hear event marshals and volunteers at all times. Headphones will be removed if seen.



# Swim in Pink

Proudly swimming in pink and supporting NBCF for 17 years!

When you purchase from Vorgee's 'swim in pink' range, you are part of the community supporting the National Breast Cancer Foundation's vision of Zero Deaths from breast cancer.



NBCF Silicone Cap



NBCF Missile Fuze



NBCF Vortech

Immerse yourself in Vorgee's product range at [vorgee.com](http://vorgee.com)



# TRIATHLON PINK AND CHARITY



**National  
Breast Cancer  
Foundation**

Triathlon Pink has been supporting breast cancer charities since the series started in 2007, and has raised over \$2.5 million for breast cancer research, support and care. Your entry fee covers event costs, so to support the National Breast Cancer Foundation you'll need to fundraise additionally or donate via our registration system.

Help the National Breast Cancer Foundation move towards their goal of zero deaths from breast cancer through these fundraising activities:

- Making an optional donation as you enter
- setting up a fundraising page
- or sponsoring a friend's fundraising!

## ABOUT THE NATIONAL BREAST CANCER FOUNDATION

The National Breast Cancer Foundation (NBCF) is Australia's leading not-for-profit organisation funding world-class breast cancer research towards our vision of Zero Deaths from breast cancer.

Since our inception in 1994, NBCF has invested around \$200M into more than 600 world-class research projects across Australia. For more information, visit [www.nbcf.org.au](http://www.nbcf.org.au)

## WHAT SHOULD YOU WEAR?



One of the most frequently asked questions we get! Basically, anything goes when it comes to Triathlon Pink - just wear whatever you are most comfortable in and what gives you the most confidence on event day. Our apparel partner [Navi for Women](#) has some gorgeous options if you're looking for bright and comfy active wear!

Most ladies wear a swimsuit in the pool (often with some kind of supportive bra or additional top underneath) and then add additional clothing such as pants and singlets when they get to their bike.



# VENUE AND PARKING

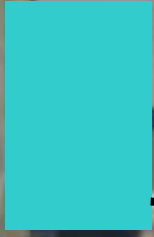









**NOTE:** Pool Transition is only open at certain times, please see the event timeline for when you can access.

Follow the white dotted lines shown on the map to access the Pool Transition area after Event Check In and Bike / Run Transition set up



**NOTE:** Bike to Run Transition is open for access from 6am for all participants. We recommend putting any gear you need here before heading to the pool.

Pool	
Pool Transition	
Bike / Run Transition	
Event Check In	
Finish Line	
Event Parking	
Bike Course	
Run Course	

# POOL TRANSITION FLOW

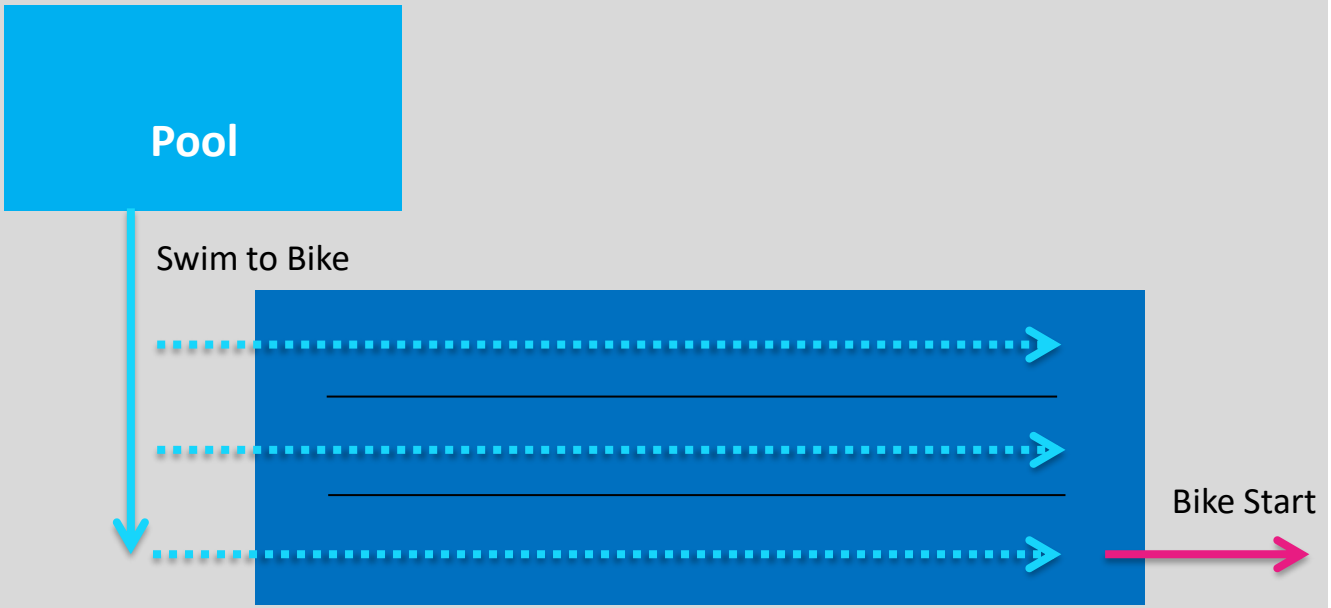

# BIK TO RUN TRANSITION FLOW

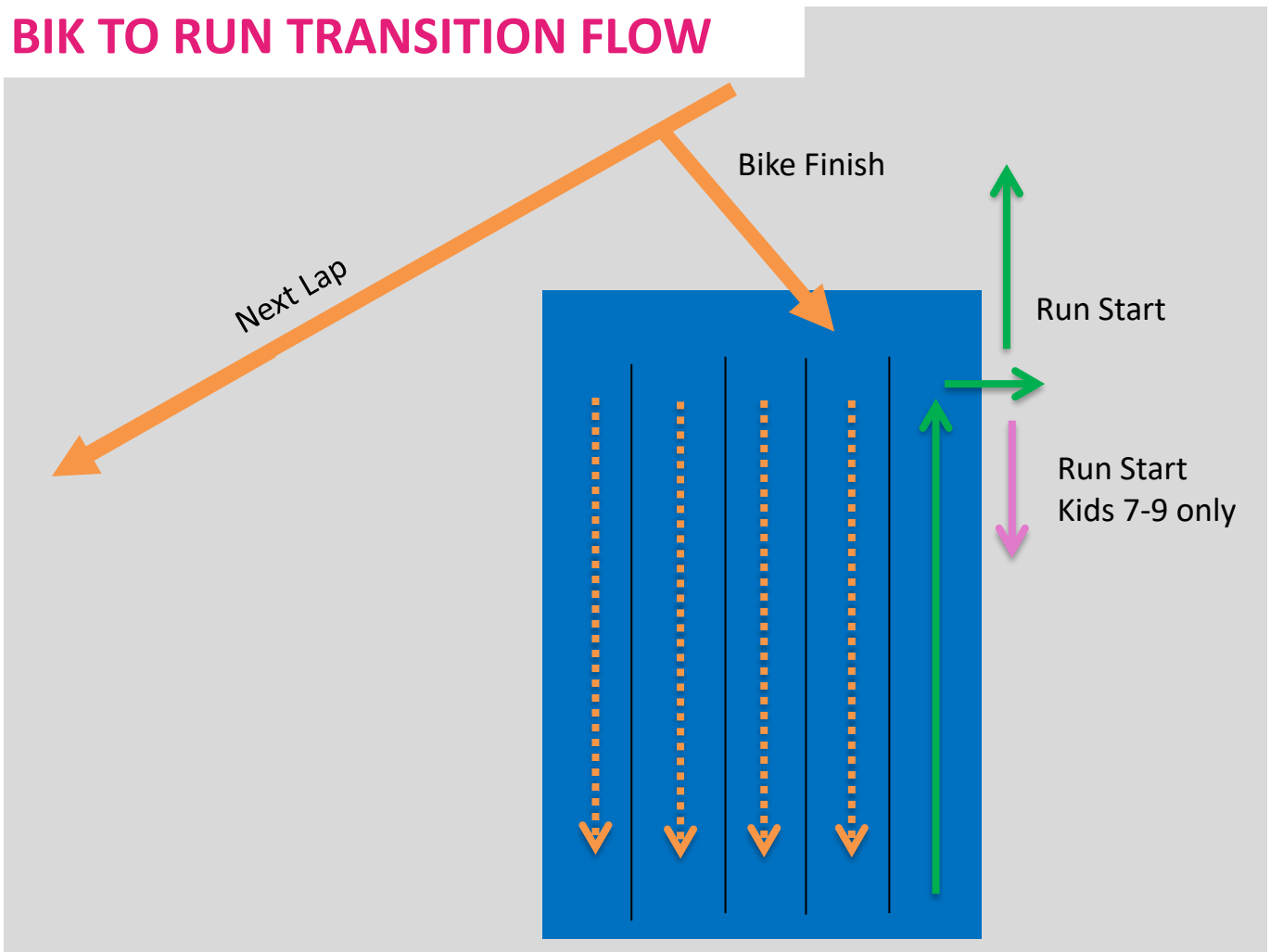

# SWIM COURSE

Next Lap Ultra

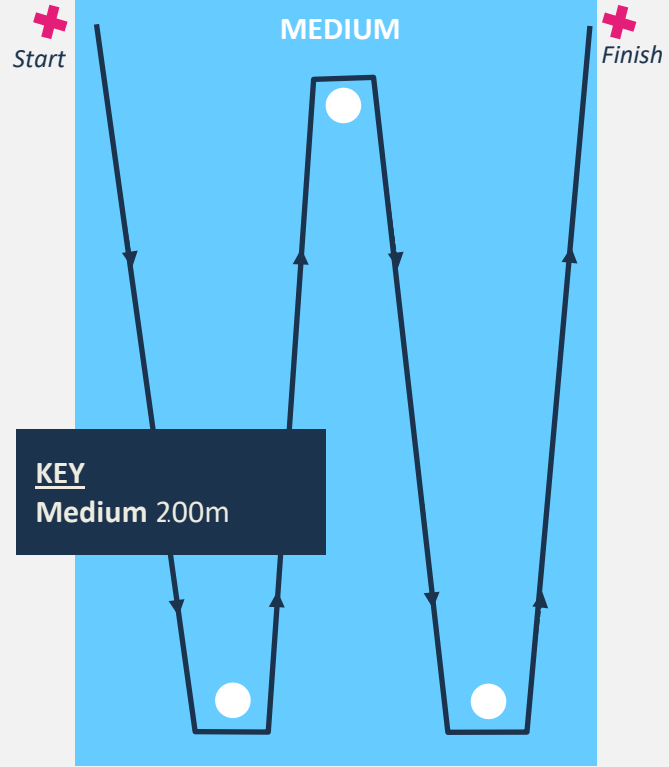
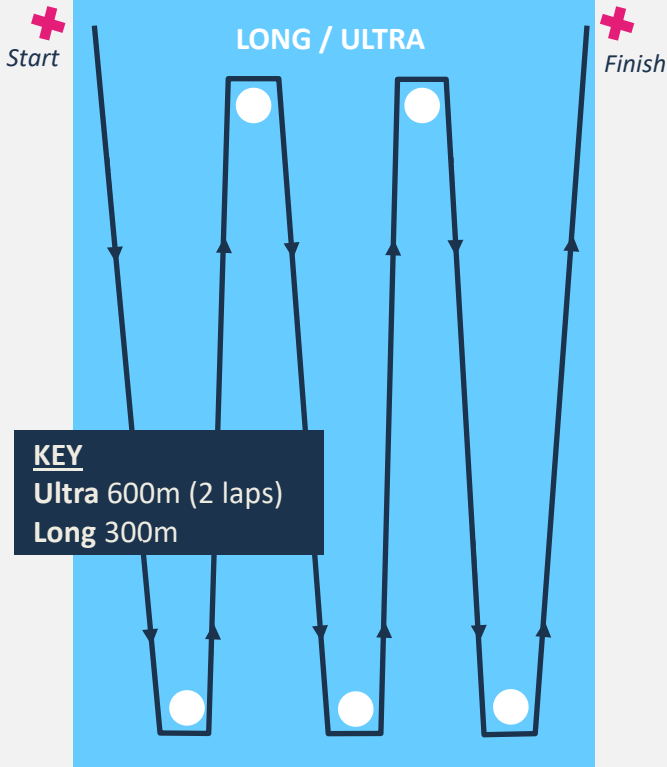

# BIKE COURSE

Bike Start

Bike Finish / Next Lap

Ultra (19km)	6 Laps
Long (9.6km)	3 Laps
Medium (6.4km)	2 Laps
Short (3.2km)	1 Lap
Kids 10-13 (3.2km)	1 Lap
Kids 7-9 (2km)	1 Lap + 1 Lap dotted

# RUN COURSE

Run Start all other distances

Run Start Kids 7-9

Next Lap

Ultra (7.5km)	3 Laps
Long (5km)	2 Laps
Medium (2.5km)	1 Lap
Short (1km)	1 Lap
Kids 10-13 (1km)	1 Lap
Kids 7-9 (500m)	1 Short Lap

The run course is a multi-loop course. Please note the short lap for Short Course and Kids 10-13 and the reverse start for Kids 7-9.



# FUN RUN COURSE

Run Start all distances

Next Lap

10km	4 Laps
5km	2 Laps
2.5km	1 Lap
1km	1 Lap

The run course is a multi-loop course. Please note the short lap for 1km.

# THANKS TO OUR EVENT PARTNERS

